

**American Standard Short Pitch Precision Roller Chain (ISO 606/ DIN 8188, GOST 13568-97 )**

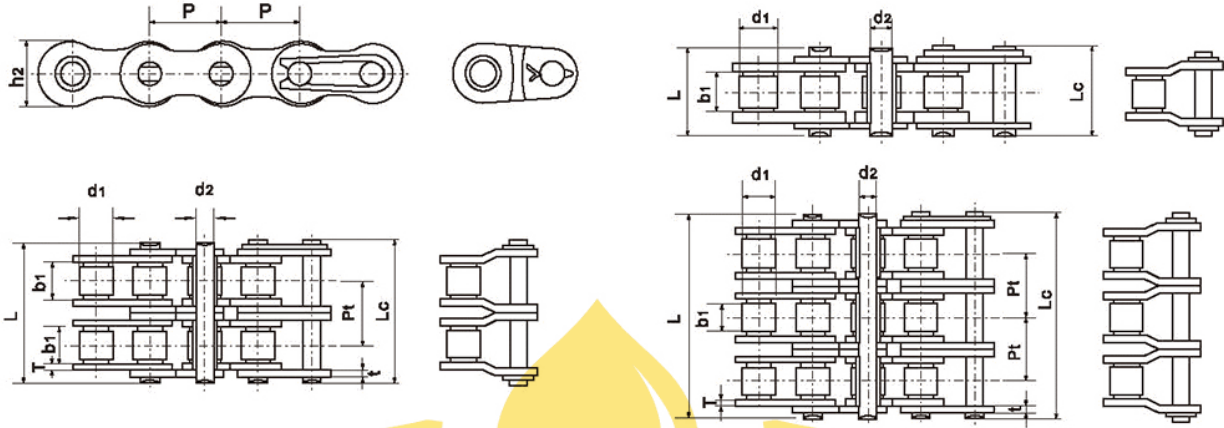

ANSI Chain No.	ISO Chain No.	P	d1	b1	d2	h2	Pt	L	Lc	U.T. S. (KN)	Wt. (Kg/m)
*15-1	*03C	4.7625	2.48	2.38	1.62	4.3	-	6.1	6.9	1.8	0.08
*25-1	*04C	6.35	3.30*	3.18	2.3	6	-	7.8	8.4	3.5	0.15
*25-2							6.4	14.5	15	7	0.28
*35-1	*06C	9.525	5.08*	4.77	3.58	9	-	12.4	13.2	7.9	0.33
*35-2							22.5	23.3	15.8	0.63	
*35-3							10.13	32.7	33.5	23.7	1.05
41-1	085	12.7	7.77	6.25	3.58	9.91	-	13.75	15	6.67	0.41
40-1	08A	12.7	7.95	7.85	3.96	12.07	-	16.6	17.8	14.1	0.62
40-2							31	32.2	28.2	1.12	
40-3							14.38	45.4	46.6	42.3	1.9
50-1	10A	15.875	10.16	9.4	5.08	15.09	-	20.7	22.2	22.2	1.02
50-2							18.11	38.9	40.4	44.4	2
50-3							57	58.5	66.6	3.09	
60-1	12A	19.05	11.91	12.57	5.94	18.08	-	25.9	27.7	31.8	1.5
60-2							22.78	48.8	50.5	63.6	2.92
60-3							71.5	73.3	95.4	4.54	
80-1	16A	25.4	15.88	15.75	7.92	24.13	-	32.7	35	56.7	2.6
80-2							29.29	62.7	64.3	113.4	5.15
80-3							91.7	93.6	170.1	7.89	
100-1	20A	31.75	19.05	18.9	9.53	30.18	-	40.4	44.7	88.5	3.91
100-2							35.76	76.4	80.5	177	7.8
100-3							112.2	116.3	265.5	11.77	
120-1	24A	38.1	22.23	25.22	11.1	36.2	-	50.3	54.3	127	5.62
120-2							45.44	95.8	99.7	254	11.7
120-3							141.4	145.2	381	17.53	
140-1	28A	44.45	25.4	25.22	12.7	42.24	-	54.4	59	172	7.5
140-2							48.87	103.3	107.9	344	15.14
140-3							152.2	156.8	517.2	22.2	
160-1	32A	50.8	28.58	31.55	14.27	48.26	-	64.8	69.6	226.8	10.1
160-2							58.55	123.3	128.1	453.6	20.14
160-3							181.8	186.6	680.4	30.02	
180-1	36A	57.15	35.71	35.48	17.46	54.31	-	72.8	78.6	280.2	13.45
180-2							65.84	138.6	144.4	560.5	29.22
180-3							204.4	210.2	840.7	38.22	
200-1	40A	63.5	39.68	37.85	19.85	60.33	-	80.3	87.2	353.8	16.15
200-2							71.55	151.9	158.8	707.6	32.24
200-3							223.5	230.4	1,061.40	49.03	
240-1	48A	76.2	47.63	47.35	23.81	72.39	-	95.5	103	510.3	23.2
240-2							87.83	183.4	190.8	1,020.60	45.23
240-3							271.3	278.6	1,530.90	71.6	

★ Bush Chain, Without roller.